

# 52" Tiered Console

## Option 1: Console with swinging mount

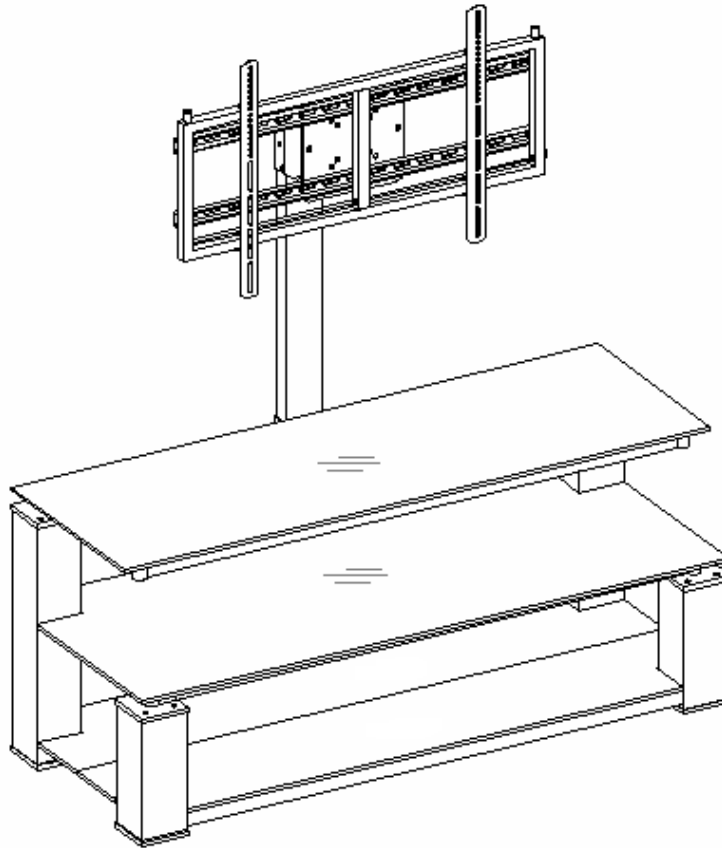

### **ADULT ASSEMBLY REQUIRED**

If you have any questions regarding assembly or if you are missing parts, do not return this item to the Retailer Store

Please call our customer service number and have your instructions and parts list ready to provide the model name,

Part name or factory number:

1-866-942-5362

Pacific Standard Time: 8:30 am - 4:30 pm Monday to Friday  
or visit our web site 24 hours a day, 7 days a week for product assistance

at [www.whalenfurniture.com](http://www.whalenfurniture.com)

or e-mail your request to [parts@whalenfurniture.com](mailto:parts@whalenfurniture.com)

MODEL No.: BBXLS52VS

LOT No.: \_\_\_\_\_

DATE OF PURCHASE: \_\_\_\_\_

  
when value and style matter

**THIS INSTRUCTION BOOKLET CONTAINS IMPORTANT SAFETY INFORMATION.  
PLEASE READ AND KEEP FOR FUTURE REFERENCE.**

VAS Furniture Mfg. Inc.

Factory No. 33-10944

Page # 1

## ASSEMBLY TIPS

Read all instructions BEFORE assembly.

Remove all hardware from box and sort by size.

Check to see that all hardware and parts are present BEFORE assembling.

Ask a friend to assist you with the assembly of this furniture.

To avoid damage, assemble the unit on a sturdy, level and non-abrasive surface.

Please wait until all steps are completed before tightening bolts.

Make sure all bolts are tightly fastened before the unit is used.

MANUFACTURER: VAS FURNITURE

CATALOG: 52" Tiered Console (BBXLS52VS)

DATE OF MANUFACTURE: November, 2008

MADE IN CHINA

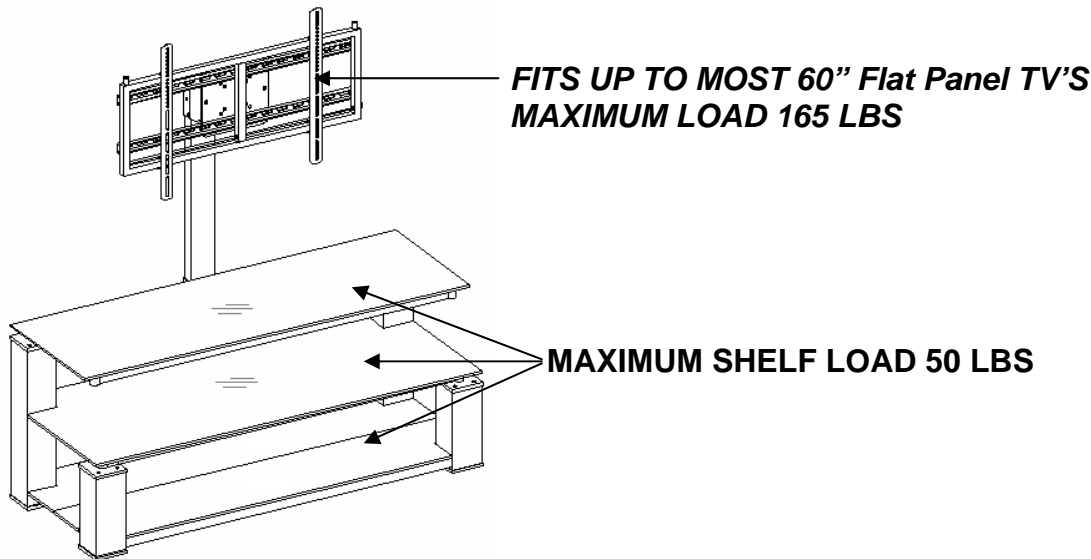

**CAUTION:** This unit is intended for use only with the products and maximum weights indicated. Use with other products or products heavier than the maximum weights indicated may result in instability causing possible injury.

**Notes: Plasma TV's with base support should be placed squarely in the center of the stand with no overhanging on either side.**

**Please call for replacement parts or assistance: 1-866-942-5362**

VAS Furniture Mfg. Inc.

Factory No. 33-10944

Page # 2

## Parts & Hardware List for Option #1

Please read completely through the instructions and verify that all parts listed are present before beginning assembly.

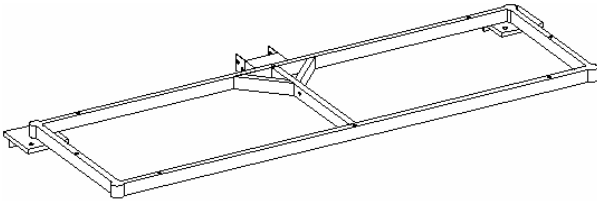

**A-Top Frame (1)**

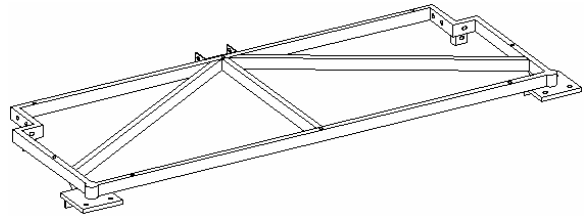

**B- Middle Shelf Frame (1)**

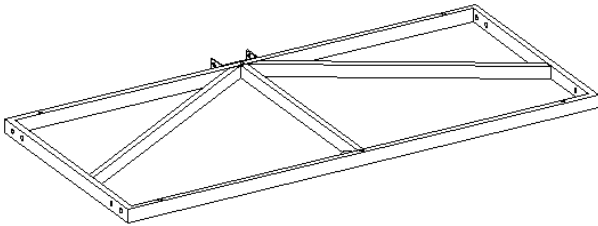

**C- Bottom Frame (1)**

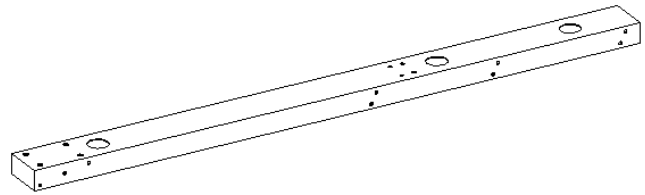

**D- Long Spine (1)**

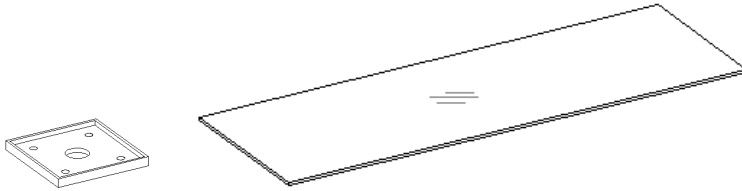

**E- Fast Mount Plate (4)**

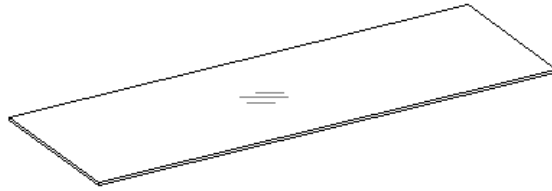

**F- Top Glass (1)**

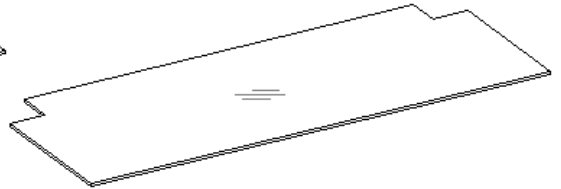

**G- Middle Glass Shelf (1)**

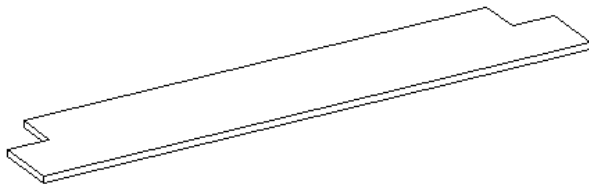

**H- Bottom Wood Shelf (2)**

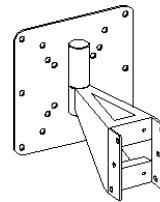

**I- Deluxe Bracket w/VESA Plate (1)**

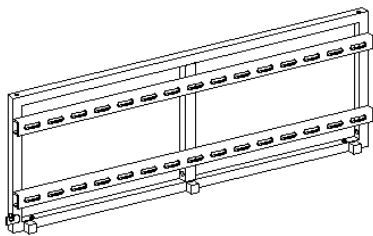

**J- XYZ Mounting Frame (1)**



**K- Monitor Bracket (2)**

Please call for replacement parts or assistance: **1-866-942-5362**

VAS Furniture Mfg. Inc.

Factory No. 33-10944

Page # 3

## Parts & Hardware List for Option #1

**Please read completely through the instructions and verify that all parts listed are present before beginning assembly.**

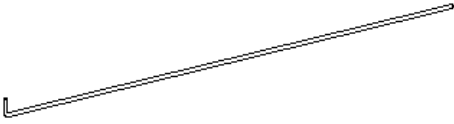

**L- Safety Bar (1)**

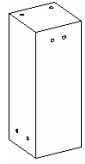

**M- Left Front Post (1)**

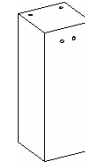

**M1- Right Front Post (1)**



**N- Left Back Post (1)**



**N1- Right Back Post (1)**

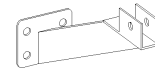

**O- Top Shelf Support (1)**



**(1) - Suction Cup (16pcs)**

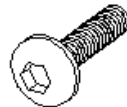

**(2) - 5/8" Bolt (32pcs)**

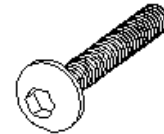

**(3) - 3/4" Bolt (4pcs)**

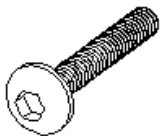

**(4) - 1" Bolt (14pcs)**

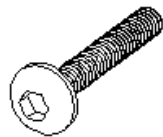

**(5) - 1 1/4" Bolt (3pcs)**

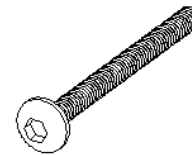

**(6) - 2 1/8" Bolt (4pcs)**



**(7) - 1" Flat Head Screw (24pcs)**



**(8) - Lock Washer (5pcs)**



**(9) - Flat Washer (9pcs)**



**(10) - Nut (5pcs)**



**(11) - Stopper (2pcs)**

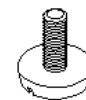

**(15) - Floor Leveler (3pcs)**



**Open Wrench  
(1)**

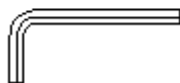

**Allen Wrench  
(1)**

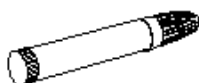

**Touch Up Pen  
(1)**

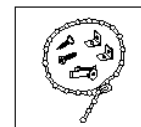

**Tipping Restraint Hardware Kit (1)  
(Inside Plastic White Bag)**

**Please call for replacement parts or assistance: 1-866-942-5362**

## TV Mounting Kit



**M4 x 12 Bolt (4)**



**M4 x 30 Bolt (4)**



**M5 X 12 Bolt (4)**



**M5 x 30 Bolt (4)**

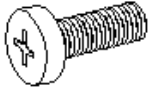

**M6 x12 Bolt (4)**

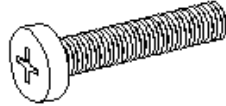

**M6 x 35 Bolt (4)**

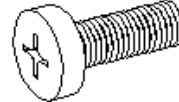

**M8x16 Bolt (4)**

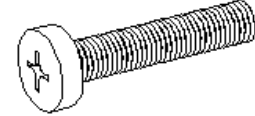

**M8 x40 Bolt (4)**



**M4 Lock Washer  
(4)**



**M5 Lock Washer  
(4)**



**M6 Lock Washer  
(4)**

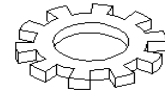

**M8 Lock Washer  
(4)**

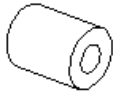

**Large Spacer (4)**



**Small Spacer (4)**

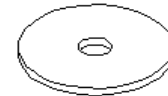

**Large Flat Washer (8)**

**Tools Required: Phillips Screwdriver, Allen Wrench (provided) and Open Wrench (provided).**

**Please do not discard any of the hardware or parts that you will not use on your set option, this will give you the opportunity to use this TV Console for different configurations in case you decide to upgrade your TV set in the future.**

**Please call for replacement parts or assistance: 1-866-942-5362**

**VAS Furniture Mfg. Inc.**

**Factory No. 33-10944**

**Page # 5**

## Assembly Instructions

**Note: Please do not fully tighten all bolts until you finish assembling all parts, then go back and fully tighten all bolts, this will make it easier during assembly of unit.**

1. Unpack the unit and confirm that you have all the hardware and required parts listed.
2. Pick up Fast Mount Plate (E) and attach to the bottom of each Post (M, M1, N & N1) with four 1" Flat Head Screws (7). See detail #1.
3. Proceed to attach Floor Leveler (15) into the center inserted nut at the bottom of Left and Right Front Posts (M & M1). See detail #1.

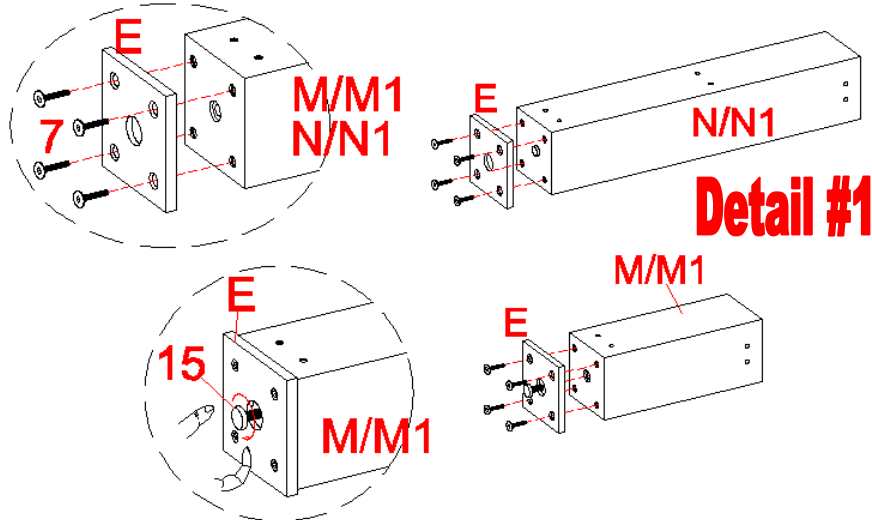

4. Pick up Bottom Frame (C) and attach a Floor Leveler (15) into the bottom tube at the center joint of front rail. See detail #2.
5. Attach Bottom Frame (C) to the bottom holes of all Posts as shown in detail #2, using eight 1" Bolts (4) through the frame holes from inside. Make sure the upper two threaded inserts on the side of post point toward back as the "U" Bracket of Bottom Frame.

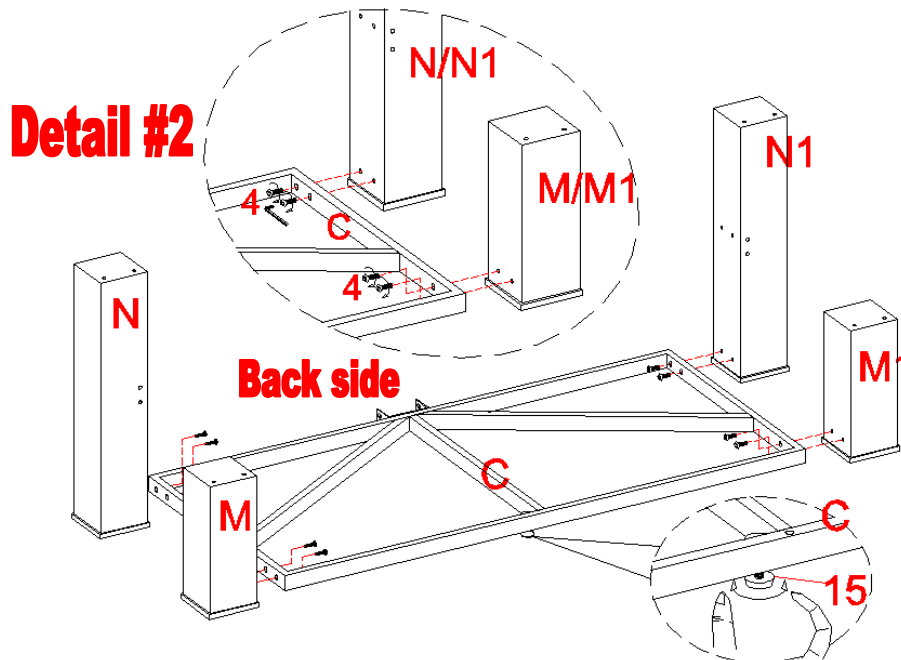

**Please call for replacement parts or assistance: 1-866-942-5362**

**VAS Furniture Mfg. Inc.**

**Factory No. 33-10944**

**Page # 6**

## Assembly Instructions

- Position the fast mount plates of Middle Shelf Frame (B) on the top of both Front Posts (M & M1) and attach to Back Posts, using one 5/8" Bolt (2) through the "L" bracket hole and three 1" Bolts (4) through frame tube holes into each back post. See detail #3.
- Secure the fast mount plates of Middle Shelf Frame onto Front Posts (M & M1) using two 5/8" Bolts (2) into back holes and two 1" Flat Head Screws (7) into top holes. As shown in detail #3A.

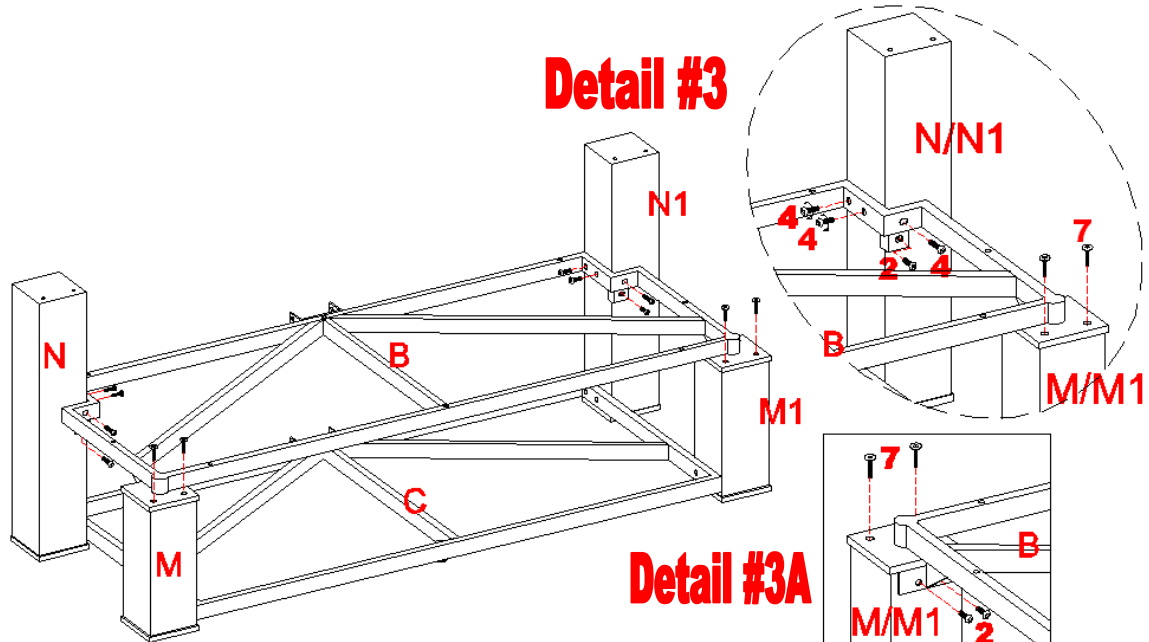

- Position the fast mount plates of Top Frame (A) on the top of Back Posts (N & N1), secure with two 5/8" Bolts (2) into back holes of mount plate and two 1" Flat Head Screws (7) into top holes into place. See detail #4.

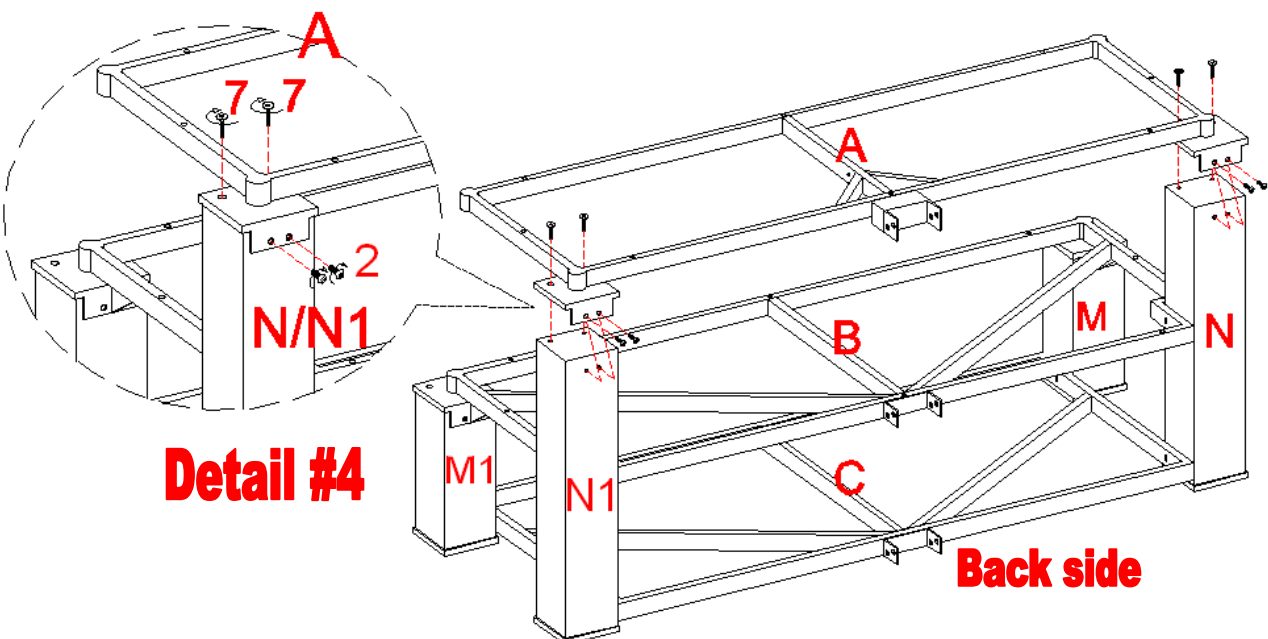

Please call for replacement parts or assistance: 1-866-942-5362

VAS Furniture Mfg. Inc.

Factory No. 33-10944

Page # 7

## Assembly Instructions

9. Attach Long Spine (D) to the “U” brackets of the Frame set (A, B & C), using twelve 5/8” Bolts (parts 2) through the bracket holes, as shown in detail #5.

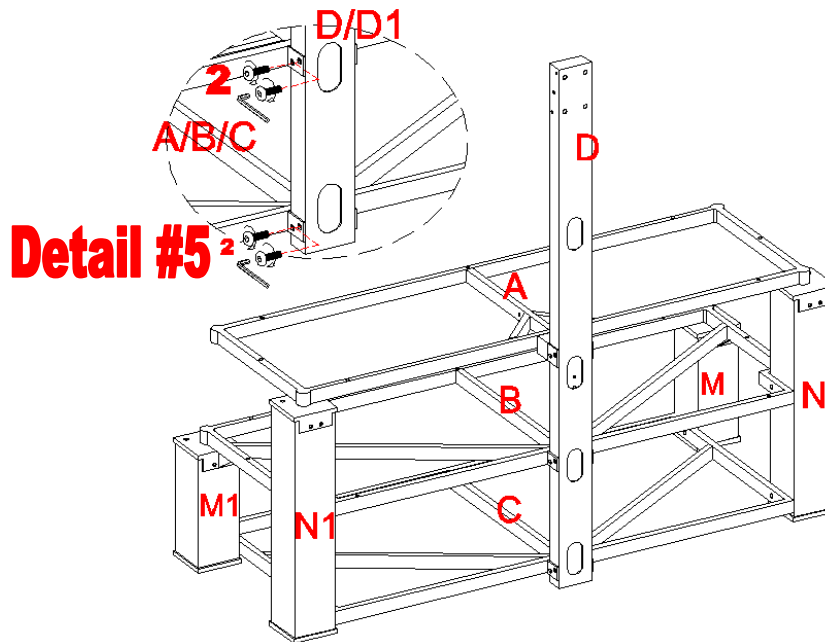

10. Attach Top Shelf Support (O) to the Long Spine (D) and Top Frame (A) in place; with the “U” bracket of Top Shelf Support is up and align with the hole of center rail of Top Frame, attach with one 1 1/4” Bolt (5) through the “U” bracket and center rail hole through Flat Washer (9) and Lock Washer (8) then secure with a Nut (10). See detail #6.
11. Proceed to attach the other end of Top Shelf Support (O) onto the Spine with four 5/8” Bolts (2). See detail #6.

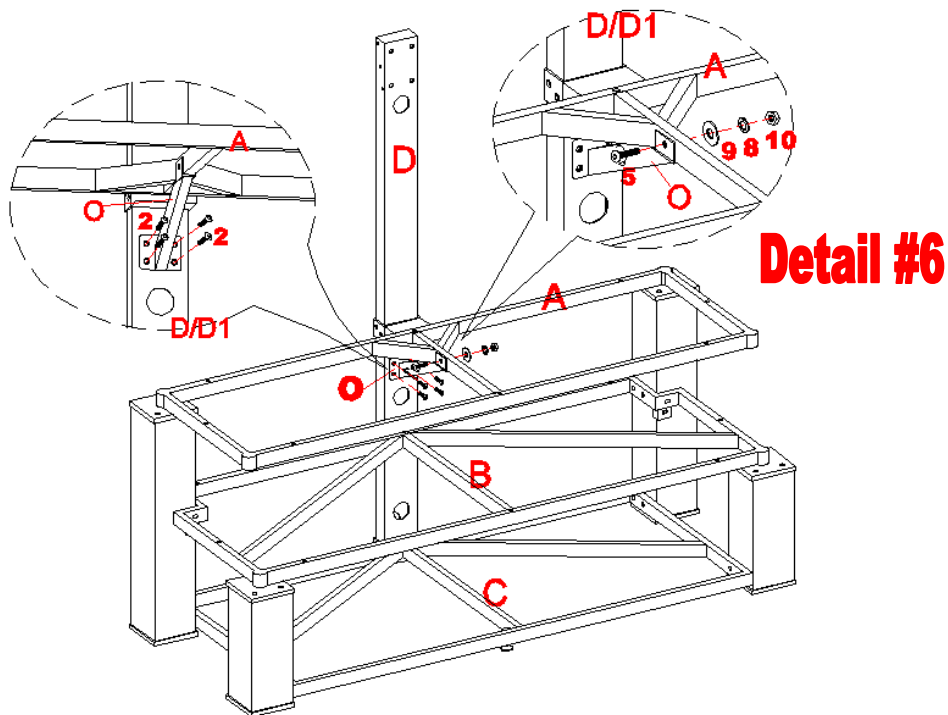

Please call for replacement parts or assistance: 1-866-942-5362

VAS Furniture Mfg. Inc.  
Factory No. 33-10944  
Page # 8



## Assembly Instructions

12. In case of uneven floor, simply tilt the unit back and use your hand to adjust the Floor Levelers (15) installed at the bottom of Front Posts (M & M1) and Bottom Frame (C), until the unit is level. See detail #7.

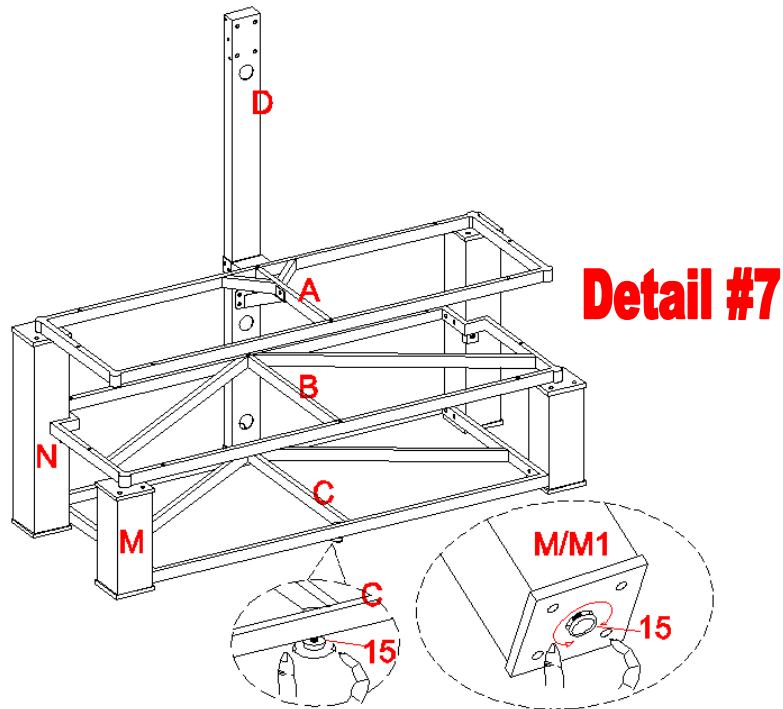

13. Attach Deluxe Bracket w/VESA Plate (I) to the Top of Long Spine (D), using six 5/8" Bolts (2) through bracket side holes and four 2 1/8" Bolts (6) through top holes of Spine as shown in detail #8.

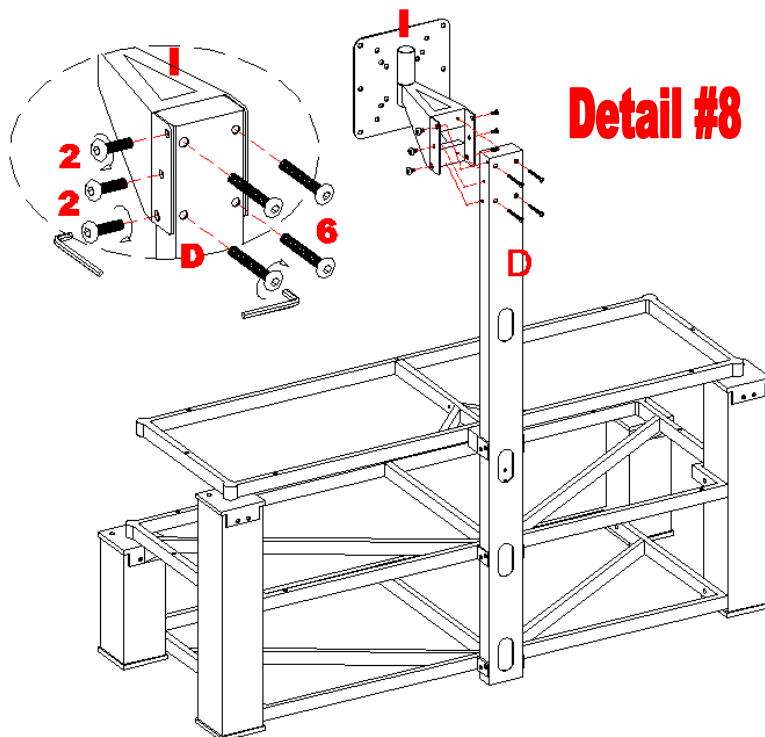

Please call for replacement parts or assistance: 1-866-942-5362

VAS Furniture Mfg. Inc.  
Factory No. 33-10944  
Page # 9

## Assembly Instructions

**Note:** There are two mounting options included in this 3-in-1 system TV console:

1. VESA Plate;
2. XYZ Mounting Frame to accommodate random hole patterns.

14. For LCD TV 32" or smaller you can mount your TV directly to the Deluxe Bracket with VESA plate (I), using the appropriate Bolts through the Lock Washers and Flat Washers through the proper holes of VESA plate and then into the TV set. See detail #9.

**Note:** Please refer to page # 11&12 to determine correct size bolt you will require in the TV Mounting Kit included. If you are unable to find the correct one, consult a local hardware store.

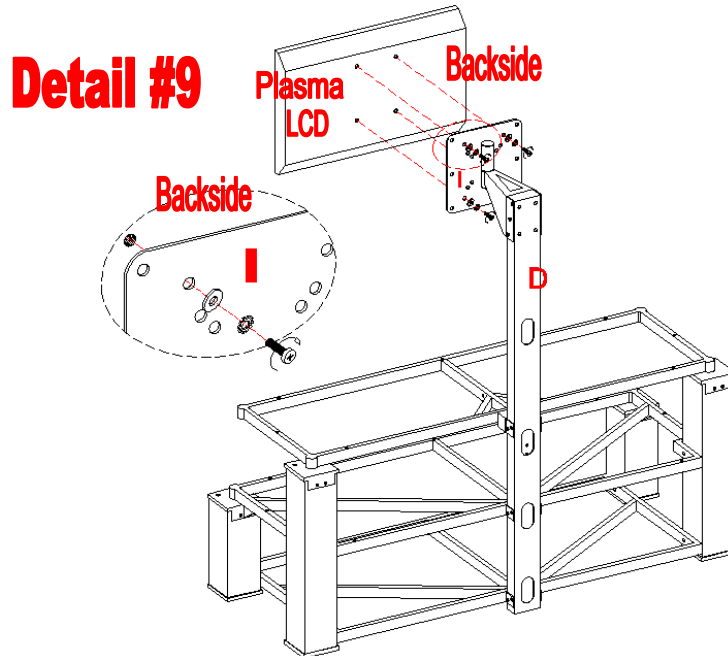

**Note:** For Plasma and LCD TVs larger than 32", you must use the XYZ Mounting Frame (J) provided. The XYZ Mounting Frame will accommodate large LCD without VESA Hole Patterns and Plasma TV's with Random Hole Patterns.

15. Repeat Steps #13 and attach the XYZ Mounting Frame (J) to the Deluxe Bracket w/VESA Plate (I), using four 3/4" Bolts (3) with Flat Washer (9) through the appropriate slots of "U" Plate on Mounting Frame and the VESA Plate holes, through a second Flat Washer (9) and Lock Washer (8) then secure with the Nut (10), as shown in detail #10.

**Go back and tighten all bolts.**

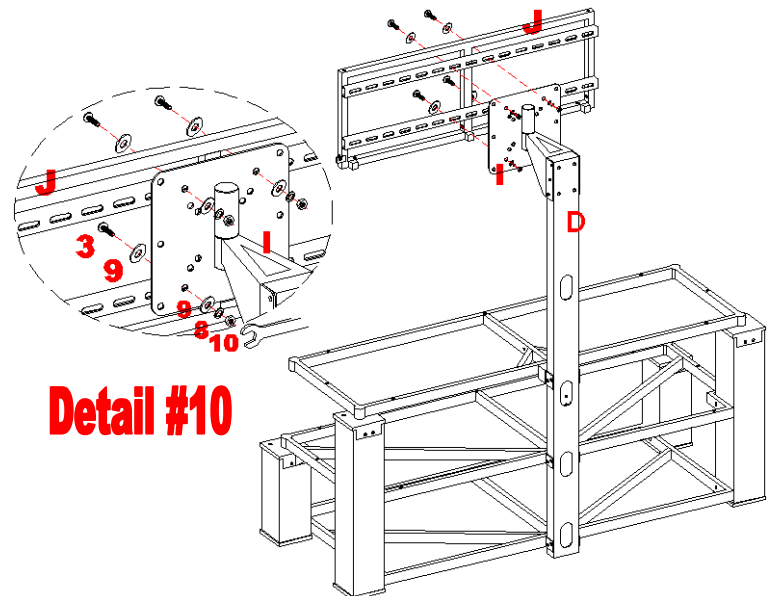

**Please call for replacement parts or assistance: 1-866-942-5362**

**VAS Furniture Mfg. Inc.**

**Factory No. 33-10944**

**Page # 10**

## Mounting Monitor Bracket to a television with a flat back

**Note: For televisions with a curved back or recessed back proceed directly to step #19.**

16. Determine the correct diameter of the bolt your TV requires by hand threading them into the threaded insert on the back of the TV. If you encounter any resistance, stop immediately. If you are unable to find the correct bolt consult a local hardware store.
17. Once you have determined the correct diameter Bolt, follow the appropriate Diagram below, thread the short Bolt through the appropriate Lock Washer, the Large Flat Washer, the Monitor Bracket (K), and into the upper threaded inserts of TV. As shown in detail #11A. **Note: Lean the TV up against a wall or other solid surface when attaching with the Monitor Brackets (K). DO NOT place the TV face down on the glass this may cause permanent damage.**
18. Proceed to insert the long Bolt through the appropriate Lock Washer, the Large Flat Washer, the slot of Monitor Bracket (K), a second Large Flat Washer (M4/M5 Diameter Bolts only), appropriate Spacer, and into the bottom threaded inserts of TV. As shown in detail #11. Make sure the Monitor Brackets (K) are centered and level with each other. Tighten the bolts securing the Monitor Brackets (K) to the TV.

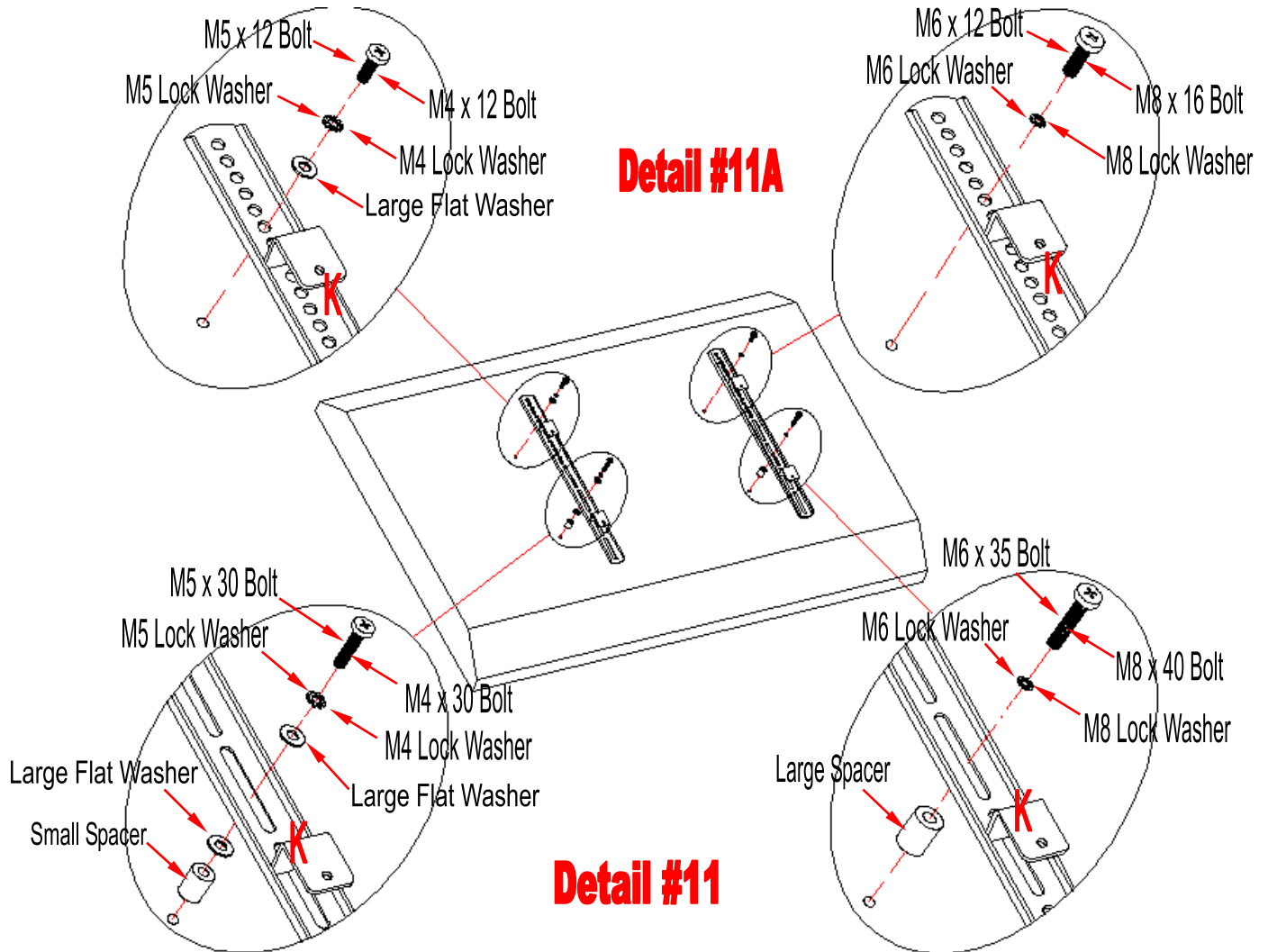

**Please call for replacement parts or assistance: 1-866-942-5362**

## Mounting Monitor Bracket to a television with a curved / recess back

- Determine the correct diameter of the bolt your TV requires by hand threading them into the threaded insert on the back of the TV. If you encounter any resistance, stop immediately. If you are unable to find the correct bolt consult a local hardware store.
- Once you have determined the correct diameter Bolt, follow the appropriate Diagram below, thread the Bolt through the appropriate Lock Washer, the Large Flat Washer, the Monitor Bracket (K), a second Large Flat Washer (M4/M5 Diameter Bolts only), appropriate Spacer and into the threaded inserts of TV.

**⚠ WARNING: DO NOT LAY THE TELEVISION FACE DOWN ON THE GLASS**

- Make sure the Monitor Brackets (K) are vertically centered and level with each other. Tighten the bolts securing the Monitor Brackets (K) to the TV.

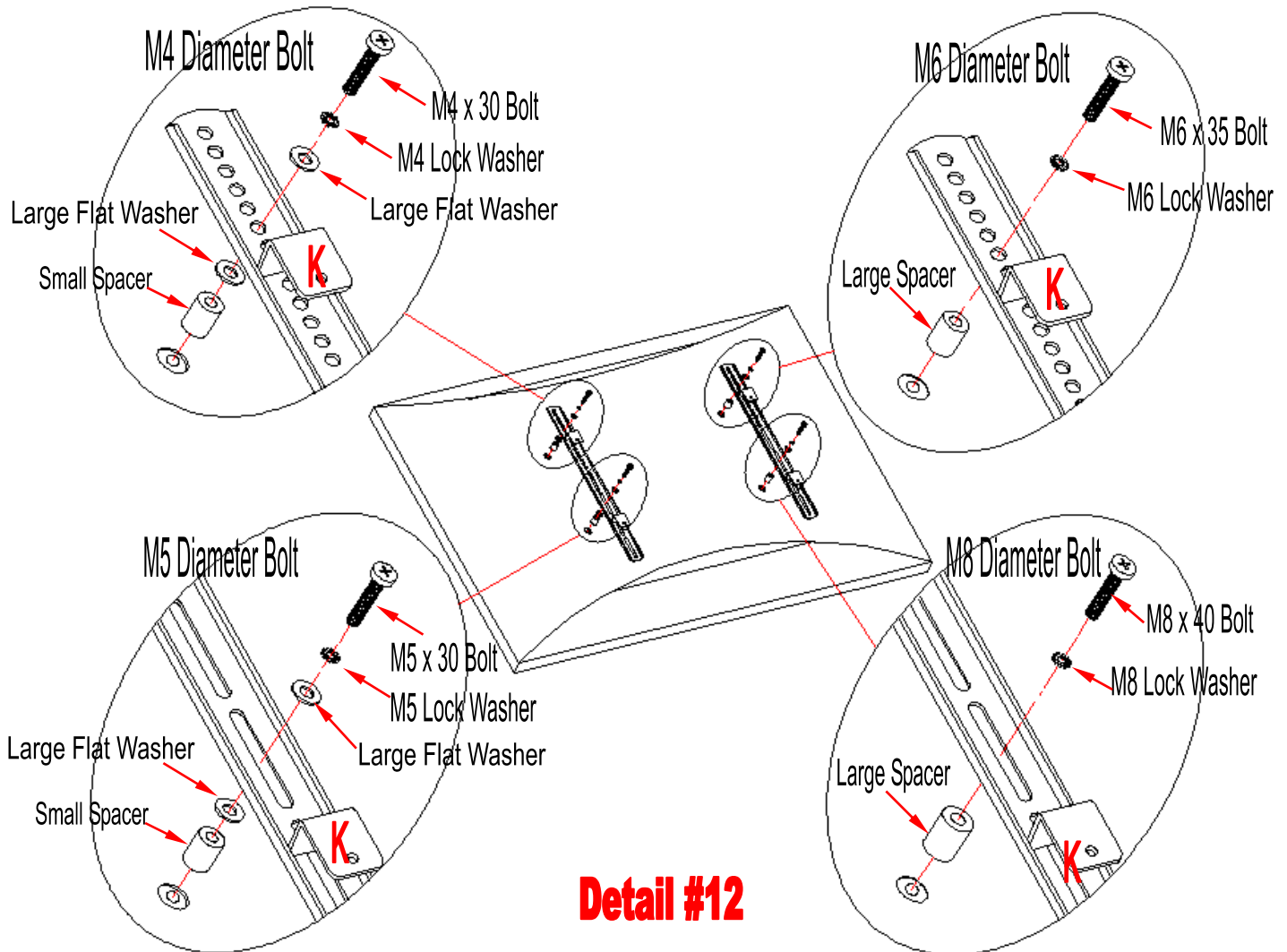

**Detail #12**

Please call for replacement parts or assistance: 1-866-942-5362

## Assembly Instructions

22. Attach two Stoppers (11) at the end of Mounting Frame (J) with 1 1/4" Bolt (5). Now you can hang your Television by attaching the Monitor Bracket (K) onto the XYZ Mounting Frame. See detail #13.
23. Once the TV is in place, insert Safety Bar (L) completely into the bottom taper holes on the XYZ Mounting Frame ensuring the Safety Bar sits over the bottom hook of the Monitor Bracket. Turn the bent end into the slot of back hook for additional security. See detail #13.

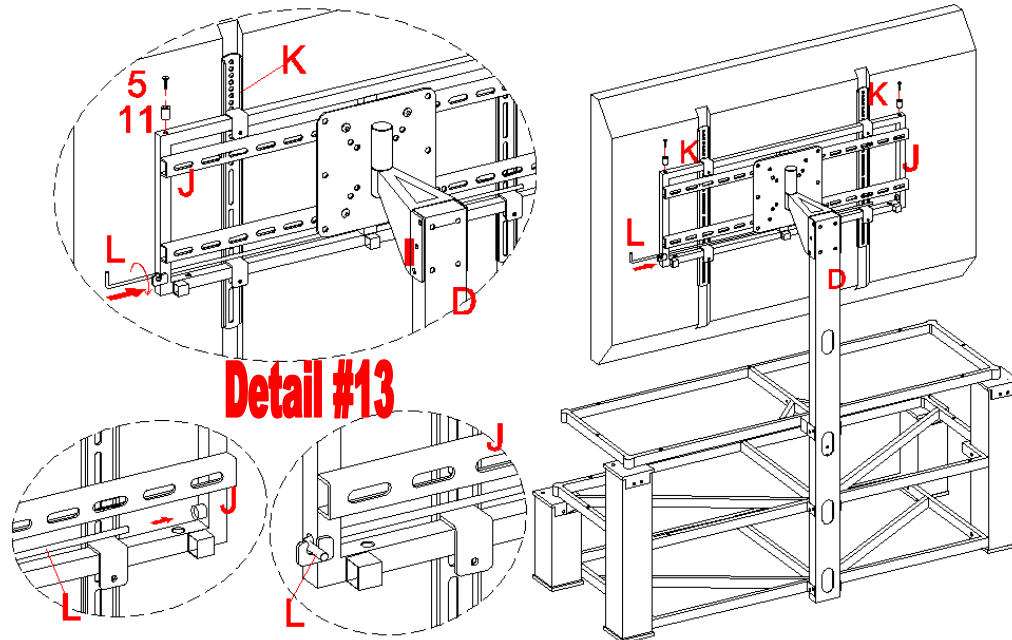

24. Insert Suction Cups (1) into top holes of Top Frame and Middle Shelf Frame (A & B) into place as shown in detail #14.
25. Place Bottom Wood Shelves (H) onto the Bottom Frame (C) by aligning the corner cut with Post as shown in detail #14. Proceed to place the Glass Shelf (F & G) in place.

**Note:** Make sure that the Glass sits correctly and goes all the way to the back of unit and the Suction Cups go all the way into the pre-drilled hole to prevent the glass shelf from falling and getting damage.

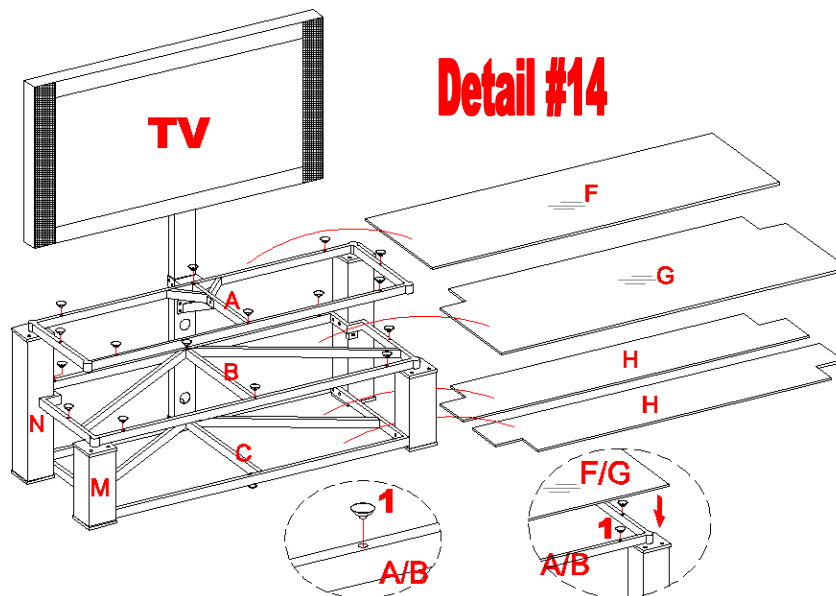

Please call for replacement parts or assistance: 1-866-942-5362

VAS Furniture Mfg. Inc.  
Factory No. 33-10944  
Page # 13

## Assembly Instructions

26. Follow the instructions printed on the plastic white bag in order to mount the Tipping Restraint Hardware Kit to the back of the Spine properly. See detail #15.

**NOTE: YOU MUST USE THIS TIPPING RESTRAINT TO ATTACH THIS UNIT TO THE WALL, TO PREVENT ACCIDENTS AND/OR INJURIES.**

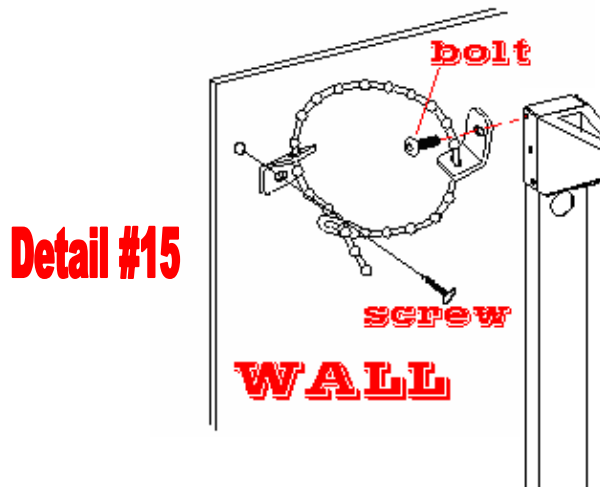

### TIPPING RESTRAINT HARDWARE

**Note: We have included one Tipping Restraint Hardware bag for this Unit. You must install this hardware to prevent accidents or injuries from falling unit.**

**When properly installed, this restraint can provide protection against the unexpected tipping of the Unit due to small tremors, bumps or climbing. We strongly recommend mounting this hardware to a wall stud and your Unit when installing.**

**Please carefully read the instructions printed on the bag.**

**Note: You must install the Tipping Restraint Hardware with the unit in use to prevent any accidents or damage to the unit.**

**Tools Required: Phillips Screwdriver, Mallet, Power Drill, 3/8" Drill Bit.**

**A Touch-Up Pen has been provided to repair any small nicks or scratches that may occur during assembly or shipping.**

**Your assembly should now be complete.  
Thank you for your purchase.**



**Please call for replacement parts or assistance: 1-866-942-5362**

**VAS Furniture Mfg. Inc.  
Factory No. 33-10944  
Page # 14**